

Article number: 604130064015

Description: Taper bored timing belt pulley
HTD 64 5M 15 TL 1210

Measures

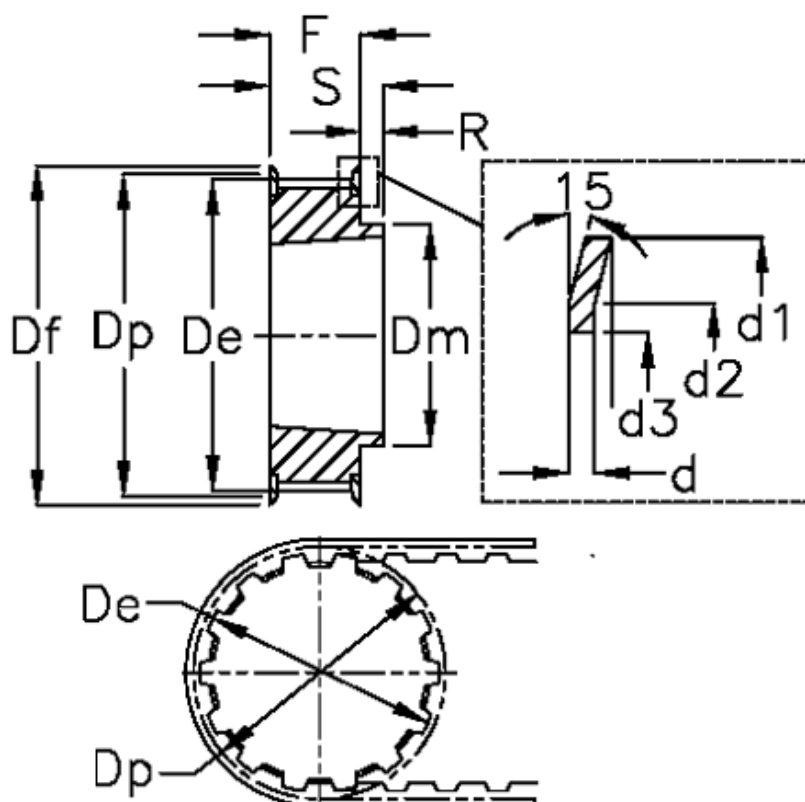

d = 1	F = 22	Weight = -
d1 = 106	Flange type = F35	Width = 15
d2 = 101	For bushing = 1210	
d3 = 90	Max bore = 32	
De = 100.72	r = 3	
Df = 106	S = 25	
Dm = 80	Tooth number = 64	
Dp = 101.86	Type = 5M	